

# SCORPION™ G2 JX 350-23

**5075**  
PSI

**23**  
L/PM

**JX750 V-TWIN**  
**PETROL**  
ENGINE TYPE

**GEARBOX**  
1450RPM  
DRIVE

**COLD**  
**WATER**  
OUTPUT

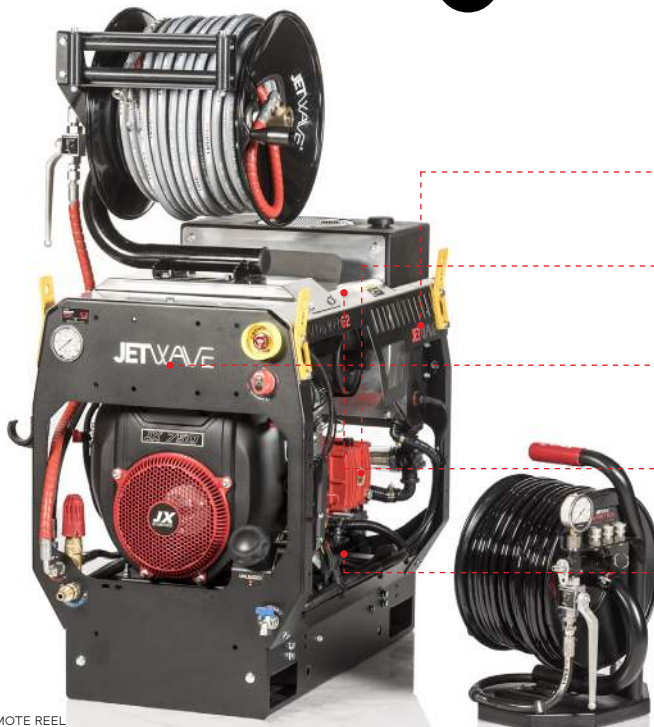

SHOWN WITH OPTIONAL REMOTE REEL

## HERO INNOVATIONS



**PEXO™**  
Stainless Steel Exoskeleton



**JWPP™**  
Jetwave Italian Premium Pump



**CC™**  
Centralised Control



**MC™**  
Multi Configuration



**AVPS™**  
Anti Vibration Protection System



**CLASS B** AS/NZS 4233.1  
WATER JETTER  
RTO CERTIFICATION IS REQUIRED FOR OPERATORS

Registered Design © 202215872

## APPLICATIONS



Plumbers



Council & Municipality



Drain Cleaning



Water Authorities



## STANDOUT FEATURES



JW® Enhanced Italian triplex plunger pump running at 1450RPM delivers more performance and longer life.



Electric start Industrial V-Twin JX750 Series Engine.



Integrated forklift pockets & mounting points. Jetwave Safety System™ (JSS) safety valve to prevent over pressurisation.



Seamless & sealed 40L on-board oversized water bypass tank with low level cut out, for unit water supply and pump protection.



Battery isolator & Emergency stop for increased safety and longevity & HGS™ Hose Reel Roller guides for better hose manoeuvrability.



Seamless under chassis mounted 25L fuel tank (w/level gauge) protected from heat with front fill point safety.

## STANDARD EQUIPMENT



Spray down gun & lance.



60m Hose reel with 60m of 3/8" jetting hose & ball valve.



IP68 Professional nozzle kit



Safety whip restraint

## DIMENSIONS (MM)

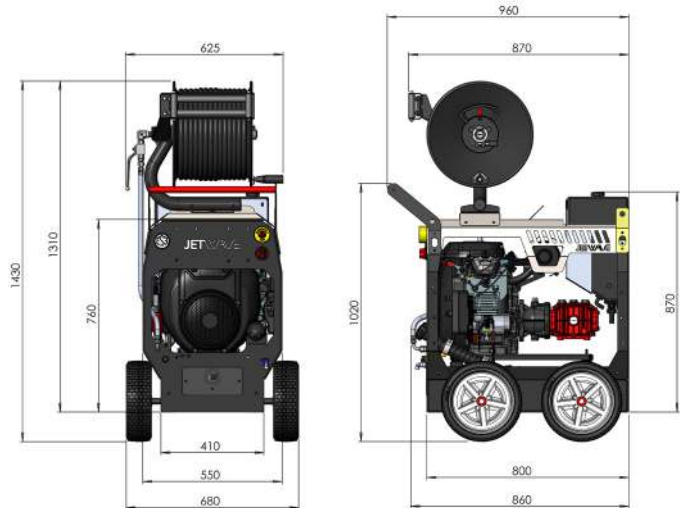

## TECHNICAL DATA 0:00

## SCORPION G2 JX 350-23

Product Code	HJ5000-23PJX
Pressure/ Flow	5075 PSI (350 BAR) / 23 L/PM
Max Water Inlet Temp	60°C
Class (ASNZS: 4223)	B (8,050 Bar/Litres)
Usage Frequency	Professional: 4 Hours Daily
Nozzle Size	05
Frame Structure	CNC Modular galvanised steel chassis plus satin powder coat finish and stainless steel cover

## MOTOR FEATURES



Engine / Power	JX750 Electric Key Start (air cooled) 24HP / 750cc
Fuel Type / Capacity / Protection	Petrol / 25L (w/level gauge) / Low Oil Shutdown

## HYDRAULIC FEATURES



Pump / Head / Pistons	JW® Italian Triplex Plunger / Brass (Nickle Plated) / Ceramic
Motor Pump Coupling / Pump RPM	Gearbox Drive / 1450RPM
Unloader Valve	Independent (Panel Mounted)
Safety Valve	Yes

## DIMENSIONS & WEIGHT



Machine Dimensions / Weight	Skid (with hose reel): 850mm(L) x 550mm(W) x 1310mm(H) / 195KG (approx.)
-----------------------------	--

## WARRANTYS



Unit / Pump Warranty*	2 Years / 3 Years
Engine Warranty*	3 Years

## OPTIONAL ACCESSORIES

## OPTIONAL UPGRADES

Remote Mini Reel w/60m 1/4" Hose	PW134-RRCMPL/HOP4	4 Wheel Trolley Kit	JWA407SEN
Remote Mini Reel Locking Plate	90012HRH-LP	Low Pressure Inlet Hose Reel w/30m hose	1065CMPLLP
Forward Root Cutting Nozzle	C43RS		
15m Viperflex Whip Hose	HOP2VFX15-ASSY		
Jetting Safety Plate	JSP		
Class B Double Action Foot Valve	55403-DA		

Copyright © 2023 Jetwave® Group Pty Ltd. All Rights Reserved.

The manufacturer reserves the right to modify design features and technical facts without notice, due to our principals of continuous improvement.

\*Coverage against defects in material and workmanship (refer to Jetwave's and component partners T&Cs).

V3.0 03/23



303 Copland Street, East Wagga Wagga NSW 2650

[equipment@amds.com.au](mailto:equipment@amds.com.au)

(02) 6921 2011 or 0428 212 011

[www.amds.com.au](http://www.amds.com.au)