

SENATOR™ G2FI 500-18



7000
480 BAR
PSI

18
L/PM

HONDA V-TWIN
iGX800 EFI PETROL
ENGINE TYPE
POWERED BY
HONDA

GEARBOX
1450RPM
DRIVE

COLD
WATER
OUTPUT



--- Optional - Trolley Kit

HERO INNOVATIONS



PEXO™
Stainless Steel Exoskeleton



JWPP™
Jetwave Italian Premium Pump



CC™
Centralised Control



EFI™
Electronic Fuel Injection Technology



MC™
Multi Configuration



Senator G2 Video



Registered Design @ 202215872

APPLICATIONS



Concrete



Line Marking Removal



Shipping & Marine



Construction

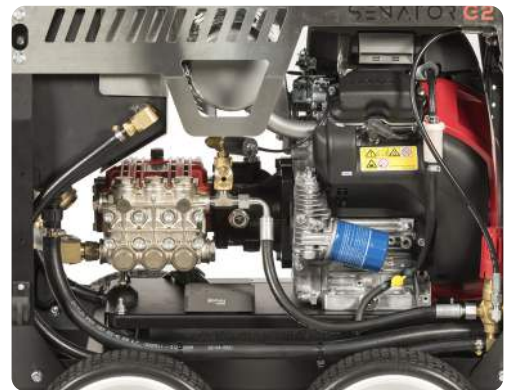

STANDOUT FEATURES



JW® UDOR® Premium Italian plunger pump running at 1450RPM, delivers more performance and longer life.



Intelligent V-Twin EFI Honda™ iGX800 industrial series engine with **auto choke & electronic fuel injection** with electric key start and digital engine hour meter.



Jetwave Safety System™ (JSS) safety valve to prevent over pressurisation.



Seamless & sealed 40L on-board oversized water bypass tank with low level cut out, for unit water supply and pump protection.



Battery isolator & Emergency stop for increased safety and longevity.



Seamless under chassis mounted 25L fuel tank (w/level gauge) protected from heat with front fill point safety.

STANDARD EQUIPMENT



Gun: RL57 spray gun with built in swivel.

Lance: S3 1200mm stainless steel vented lance.



Hose: 15m non marking double wire braid hose w/M24 couplings.

DIMENSIONS (MM)

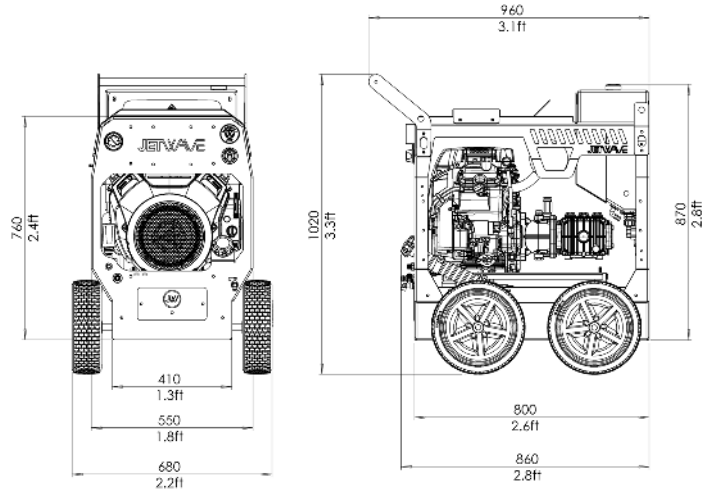

TECHNICAL DATA 0:00

SENATOR G2FI 500-18

Product Code	CW7000-18PEG2FI
Pressure / Flow Rate	7000 PSI (480 BAR) / 18 L/PM (1080 L/PH) / 4.75 GPM
Max Water Inlet Temperature	60°C / 140°F
Class (AS/NZS: 4223)	B (8,640 Bar/Litres)
Usage Frequency	Professional: Daily
Nozzle Size	O35
Frame Structure	CNC Modular galvanised steel chassis plus satin powder coat finish and stainless steel cover

MOTOR FEATURES

Engine / Power	Honda™ iGX800 EFI Electric Start (air cooled) 25 HP / 800cc
Fuel Type / Capacity / Protection	Unleaded / 25L (w/level gauge) / Low Oil Shutdown

HYDRAULIC FEATURES

Pump / Head / Pistons	JW® UDOR® Premium Triplex Plunger / Brass (Nickle Plated) / Ceramic
Motor Pump Coupling / Pump RPM	Gearbox Drive / 1450RPM
Unloader Valve	Independent (Panel Mounted)
Safety Valve	Yes

DIMENSIONS & WEIGHT

Machine Dimensions / Weight	Skid: 860mm(L) x 550mm(W) x 870mm(H) / 150KG (approx.)
-----------------------------	--

WARRANTY(S)

Unit / Pump Warranty*	2 Years
Engine Warranty*	3 Years

OPTIONAL ACCESSORIES

UR60 Turbo Nozzle (600 BAR) 25146035

OPTIONAL UPGRADES

4 Wheel Trolley Kit JWA407-S

Copyright © 2023 Jetwave® Group Pty Ltd. All Rights Reserved.

The manufacturer reserves the right to modify design features and technical facts without notice, due to our principals of continuous improvement.

*Coverage against defects in material and workmanship (refer to Jetwave's and component partners T&Cs).

V3.0 08/23



303 Copland Street, East Wagga Wagga NSW 2650

equipment@amds.com.au

(02) 6921 2011 or 0428 212 011

www.amds.com.au