

# SENATOR™ G2D 500-18



**7250**  
500 BAR  
**PSI**

**18**  
L/PM

**KOHLER KDW1003**  
LIQUID COOLED DIESEL  
ENGINE TYPE  
KOHLER.Diesel

**GEARBOX**  
1450RPM  
DRIVE

**COLD**  
WATER  
OUTPUT



## HERO INNOVATIONS



**TLL™**  
Top Lifting Lugs



**PEXO™**  
Stainless Steel Exoskeleton



**JWPP™**  
Jetwave Italian Premium Pump



**LCE™**  
Liquid Cooled Diesel Engine



**AVPS™**  
Anti Vibration Protection System



**CLASS B** AS/NZS 4233.1  
HIGH PRESSURE CLEANER  
RTO CERTIFICATION IS REQUIRED FOR OPERATORS



## APPLICATIONS



Tradesmen



Factories & Manufacturing



Mine Sites



Offshore Oil & Gas



## STANDOUT FEATURES



JW® UDOR® Premium Italian plunger pump running at 1450RPM, delivers more performance and longer life.



Industrial liquid cooled Kohler™ KDW1003 24HP fuel injected diesel engine, electric start with hour metre.



Jetwave Safety System™ (JSS) safety valve to prevent overheating in excessive bypass and over pressurisation.



Seamless & sealed 40L on-board oversized water bypass tank w/low level cut out, for unit water supply and pump protection.



Battery isolator & Emergency stop for increased safety and longevity.



Seamless under chassis mounted 25L fuel tank (w/level gauge) protected from heat.

## STANDARD EQUIPMENT



Gun: RL57 spray gun with built in swivel.

Lance: S3 1200mm stainless steel vented lance.



Hose: 15m non marking double wire braid hose w/M24 couplings.

## DIMENSIONS (MM)

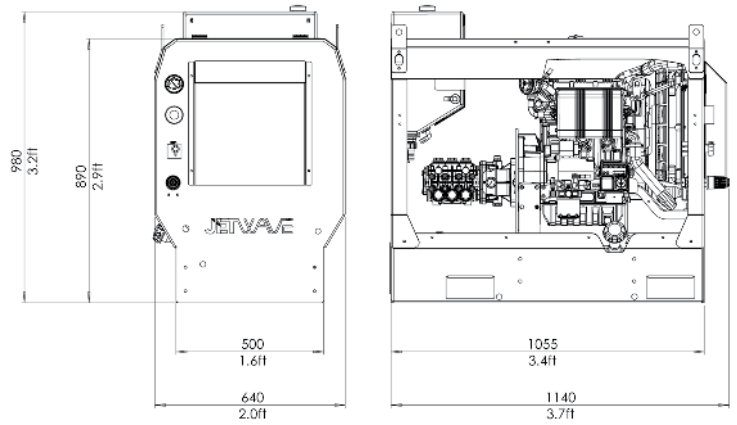

## TECHNICAL DATA 0:00

## SENATOR™ G2D 500-18

Product Code	CW7000-18DG2
Pressure / Flow Rate	7250 PSI (500 BAR) / 18 L/PM (1080 L/PH) / 4.75 GPM
Max Water Inlet Temp	60°C / 140°F
Class (AS/NZS: 4223)	Class B (9,000 Bar/Litres)
Usage Frequency	Professional: Daily Usage
Nozzle Size	035
Frame Structure	CNC Modular galvanised steel chassis plus satin powder coat finish and <b>stainless steel cover</b>

## MOTOR FEATURES

Engine / Power	Kohler™ KDW1003 Electric Key Start (3 cylinder liquid cooled) 24HP / 1028cc
Fuel Type / Capacity / Protection	Diesel / 25L (w/level gauge) / Low Oil Shutdown

## HYDRAULIC FEATURES

Pump / Head / Pistons	JW® UDOR® Premium Triplex Plunger / Brass (Nickle Plated) / Ceramic
Motor Pump Coupling / Pump RPM	Gearbox Drive / 1450RPM
Unloader Valve	Independent
Safety Valve	Yes

## DIMENSIONS & WEIGHT

Machine Dimensions / Weight	Skid: 1130mm(L) x 640mm(W) x 980mm(H) / 280KG (approx.)
-----------------------------	---

## WARRANTY(S)

Unit / Pump Warranty*	 2 Years
Engine Warranty*	 3 Years

## OPTIONAL ACCESSORIES

UR60 Turbo Nozzle (600 BAR)	25146035
-----------------------------	----------

Copyright © 2023 Jetwave® Group Pty Ltd. All Rights Reserved.

The manufacturer reserves the right to modify design features and technical facts without notice, due to our principals of continuous improvement.

\*Coverage against defects in material and workmanship (refer to Jetwave's and component partners T&Cs).

V3.0 08/23



 303 Copland Street, East Wagga Wagga NSW 2650

 [equipment@amds.com.au](mailto:equipment@amds.com.au)

 (02) 6921 2011 or 0428 212 011

 [www.amds.com.au](http://www.amds.com.au)