

SENATOR™ G2 JX 280-26



4060
280 BAR
PSI

26
L/PM

JX750 V-TWIN
PETROL
ENGINE TYPE

GEARBOX
1450RPM
DRIVE

COLD
WATER
OUTPUT



--- Optional - Trolley Kit

HERO INNOVATIONS



PEXO™
Stainless Steel Exoskeleton



JWPP™
Jetwave Italian Premium Pump



CC™
Centralised Control



AVPS™
Anti Vibration Protection System



MC™
Multi Configuration



APPLICATIONS

- Tradesmen
- Commercial Cleaners
- Shipping & Logistics
- Construction



STANDOUT FEATURES

- JW® UDOR® Premium Italian plunger pump running at 1450RPM, delivers more performance and longer life.
- Electric start Industrial V-Twin JX750 Series Engine.
- Jetwave Safety System™ (JSS) safety valve to prevent over pressurisation.
- Seamless & sealed 40L on-board oversized water bypass tank w/low level cut out, for unit water supply and pump protection.
- Battery isolator & Emergency stop for increased safety and longevity.
- Seamless under chassis mounted 25L fuel tank (w/level gauge) protected from heat with front fill point safety.

STANDARD EQUIPMENT



Gun: J5500k low trigger force gun w/swivel & lance coupling system.

Lance: JW Straight stainless steel lance w/ snap coupling + nozzle w/protector & tail



Hose: 15m non marking double wire braid hose w/M22 couplings



Chemical: JW easy foam kit w/IL bottle

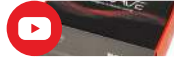

G2 WASHBOX VIDEO

DIMENSIONS (MM)

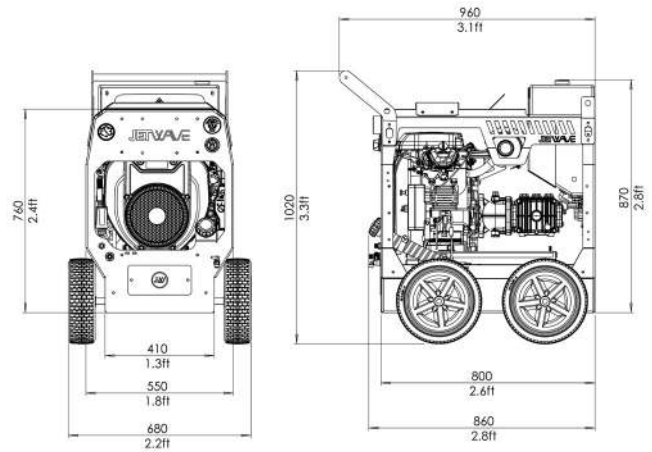

TECHNICAL DATA

SENATOR G2 JX 280-26

Product Code	CW4000-26PEG2JX
Pressure / Flow Rate	4060 PSI (280 BAR) / 26 L/PM (1,560 L/PH) / 6.6 GPM
Max Water Inlet Temp	60°C / 140°F
Class (AS/NZS: 4223)	B (7,280 Bar/Litres)
Usage Frequency	Professional: Daily Usage
Nozzle Size	O65
Frame Structure	CNC Modular galvanised steel chassis plus satin powder coat finish and stainless steel cover

MOTOR FEATURES

Engine / Power	JX750 Electric Start (air cooled) 24HP / 750cc
Fuel Type / Capacity / Protection	Unleaded / 25L (w/level gauge) / Low Oil Shutdown



HYDRAULIC FEATURES

Pump / Head / Pistons	JW® UDOR® Premium Triplex Plunger / Brass (Nickle Plated) / Ceramic
Motor Pump Coupling / Pump RPM	Gearbox Drive / 1450RPM
Unloader Valve	Independent (Panel Mounted)
Safety Valve	Yes

DIMENSIONS & WEIGHT

Machine Dimensions / Weight	Skid: 850mm(L) x 550mm(W) x 760mm(H) / 150KG (approx.)
-----------------------------	--

WARRANTY(S)

Unit / Pump Warranty*	 2 Years
Engine Warranty*	 3 Years

OPTIONAL ACCESSORIES

OPTIONAL UPGRADES

30m Hose Reel w/30m total hose	1060CMPL-SEN30M	4 Wheel Trolley Kit	JWA407-S
60m Hose Reel w/60m total hose	1067CMPL-SEN60M	Hose Reel Roller Guide System HGS™	1067-GUIDEASSY (1067 Only)
JW Pro Turbo Head	JWA303-O65		
21" Hammerhead - Stainless Steel	JWA-FSC22-5.06		
30" Hammerhead - Stainless Steel	JWA-FSC30.06		

Copyright © 2023 Jetwave® Group Pty Ltd. All Rights Reserved.

The manufacturer reserves the right to modify design features and technical facts without notice, due to our principals of continuous improvement.

*Coverage against defects in material and workmanship (refer to Jetwave's and component partners T&Cs).

V3.0 08/23



 303 Copland Street, East Wagga Wagga NSW 2650

 equipment@amds.com.au

 (02) 6921 2011 or 0428 212 011

 www.amds.com.au