

SCORPION™ G2 280-26

4060
275 BAR
PSI

26
L/PM

HONDA V-TWIN
GX690 PETROL
ENGINE TYPE
POWERED BY
HONDA

GEARBOX
1450RPM
DRIVE

COLD
WATER
OUTPUT

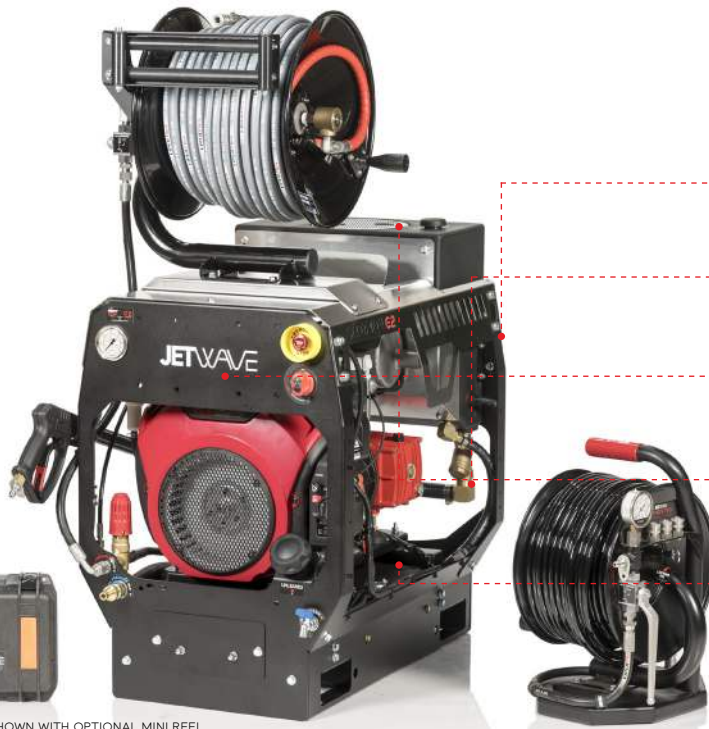

SHOWN WITH OPTIONAL MINI REEL

HERO INNOVATIONS



PEXO™
Stainless Steel Exoskeleton



JWPP™
Jetwave Italian Premium Pump



CC™
Centralised Control



MC™
Multi Configuration



AVPS™
Anti Vibration Protection System



CLASS B AS/NZS 4233.1
WATER JETTER
RTO CERTIFICATION IS REQUIRED FOR OPERATORS



Registered Design © 202215872

APPLICATIONS



Plumbers



Council & Municipality



Drain Cleaning



Water Authorities



STANDOUT FEATURES



JW® Enhanced Italian triplex plunger pump running at 1450RPM delivers more performance and longer life.



Electric start Industrial V-Twin **Honda™ GX690** Series Engine, with digital engine hour meter.



Integrated forklift pockets & mounting points. **Jetwave Safety System™ (JSS)** safety valve to prevent over pressurisation.



Seamless & sealed **40L on-board oversized water bypass tank** with low level cut out, for unit water supply and pump protection.



Battery isolator & Emergency stop for increased safety and longevity.



Seamless under chassis mounted **25L fuel tank** (w/level gauge) protected from heat with front fill point safety.

STANDARD EQUIPMENT



Gun: J5500k low trigger force gun w/swivel & lance coupling system.

Lance: JW Straight stainless steel lance w/snap coupling + nozzle w/protector & tail



Hose: 60m 3/8" jetting hose.

Hose Reel: 60m Pro rapid style w/ball valve & hose reel roller guides (HGS™)



Nozzles: JW Professional nozzle kit IP68 w/pelican case.

Safety: Hose whip restraint.



G2 WASHBOX VIDEO

MULTIPLE CONFIGURATIONS AVAILABLE



DIMENSIONS (MM)

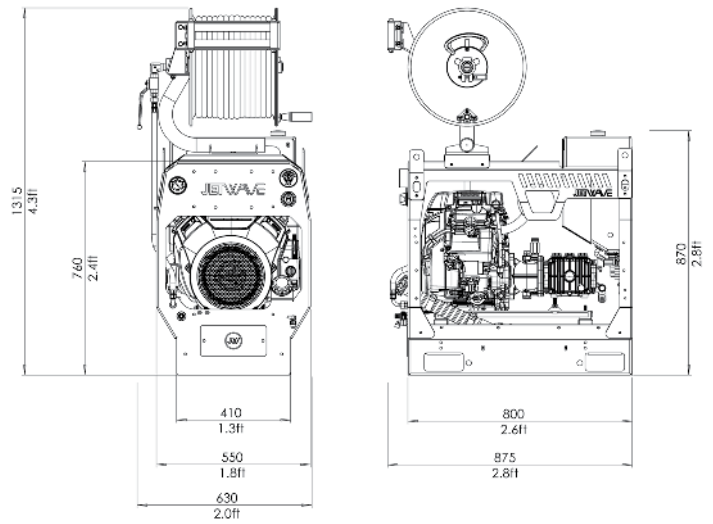

TECHNICAL DATA

SCORPION™ G2 280-26

Product Code	HJ4350-26PH
Pressure/ Flow	4060 PSI (280 BAR) / 26 L/PM
Max Water Inlet Temp	60°C
Class (AS/NZS: 4223)	B (7,280 Bar/Litres)
Usage Frequency	Professional: Daily
Nozzle Size	O65
Frame Structure	CNC Modular galvanised steel chassis plus satin powder coat finish and stainless steel cover

MOTOR FEATURES

Engine / Power	Honda™ GX690 Electric Key Start (air cooled) 23HP / 690cc
Fuel Type / Capacity / Protection	Petrol / 25L (w/level gauge) / Low Oil Shutdown

HYDRAULIC FEATURES

Pump / Head / Pistons	JW® UDOR® Premium Triplex Plunger / Brass (Nickle Plated) / Ceramic
Motor Pump Coupling / Pump RPM	Gearbox Drive / 1450RPM
Unloader Valve	Independent (Panel Mounted)
Safety Valve	Yes

DIMENSIONS & WEIGHT

Machine Dimensions / Weight	Skid No Hose Reel: 875mm(L) x 550mm(W) x 870mm(H) / 195KG (approx.)
-----------------------------	---

WARRANTYS

Unit / Pump Warranty*	 2 Years / 3 Years
Engine Warranty*	 3 Years

OPTIONAL ACCESSORIES

Remote Mini Reel w/60m 1/4" Hose	PW134-RRCMPL/HOP4
Remote Mini Reel Locking Plate	90012HRH-LP
Forward Root Cutting Nozzle	C43RS
15m Viperflex Whip Hose	HOP2VFX15-ASSY
Jetting Safety Plate	JSP
Class B Double Action Foot Valve	55403-DA

OPTIONAL UPGRADES

Van Alloy Drip Tray + Exhaust Mod	JWA432
4 Wheel Trolley Kit	JWA407A
Front Double Stack Kit	JWA429
Top Double Stack Kit	JWA430
Low Pressure Inlet Hose Reel w/30m hose	1065CMPLLP
Remote Start/Stop	00030

Copyright © 2023 Jetwave® Group Pty Ltd. All Rights Reserved.

The manufacturer reserves the right to modify design features and technical facts without notice, due to our principals of continuous improvement.

*Coverage against defects in material and workmanship (refer to Jetwave's and component partners T&Cs).

V3.2 09/23