

HORNET™ G2 JNR



3000
200 BAR
PSI

11
L/PM

HONDA GX200
PETROL
ENGINE TYPE
POWERED by HONDA.

GEARBOX
1450RPM
DRIVE

COLD
WATER
OUTPUT



HERO INNOVATIONS



PEXO™
Stainless Steel Exoskeleton



TLL™
Top Lifting Lug



AFW™
Anti Flat Wheels



AVPS™
Anti Vibration Protection System



JWPP™
JW® UDOR® Premium Pump

LEARN MORE



Horner G2 Video



Registered Design ® 202215871

APPLICATIONS

- Tradesmen
- Commercial Cleaners
- Agriculturist
- Construction



STANDOUT FEATURES



JW® UDOR® Italian plunger pump running at 1450RPM, delivers more performance and longer life.



Industrial Honda™ GX200 Series Engine that delivers performance and reliability.



Jetwave Safety System™ (JSS) thermal and safety valve to prevent overheating in excessive bypass and over pressurisation.



Zero line pressure unloader valve, with stainless steel pressure gauge.



Anti flat all terrain wheels for reliable portability on site.



Emergency stop for increased operator safety.

STANDARD EQUIPMENT



Gun: J5500k low trigger force gun w/swivel & lance coupling system.

Lance: JW Straight stainless steel lance w/ snap coupling + nozzle w/protector & tail



Hose: 15m non marking double wire braid hose w/M22 couplings



Chemical: JW easy foam kit w/1L bottle

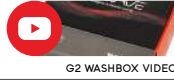

G2 WASHBOX VIDEO

DIMENSIONS (MM)

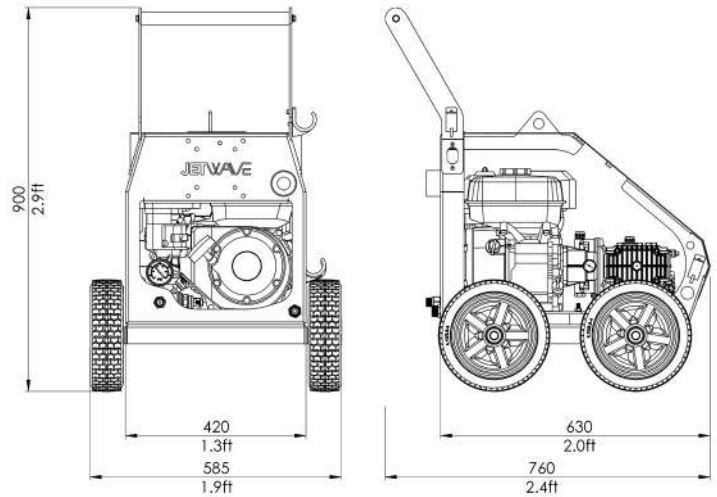

TECHNICAL DATA

HORNET™ G2 JNR

Product Code	CW3000-11PG2
Pressure / Flow Rate	3000PSI (200 BAR) / 11 L/PM (660 L/PH) / 2.9 GPM
Max Water Inlet Temp	60°C / 140°F
Class (AS/NZS: 4223)	A (2,200 Bar/Litres)
Usage Frequency	Professional: Daily
Nozzle Size	03
Frame Structure	CNC Modular skid galvanised steel chassis plus satin powder coat finish and stainless steel cover

MOTOR FEATURES

Engine / Power	Honda™ GX200 Pull Start (air cooled) 6.5HP / 200cc
Fuel Type / Capacity / Protection	Unleaded / 3.1L / Low Oil Shutdown



HYDRAULIC FEATURES

Pump / Head / Pistons	JW® Italian Triplex Plunger / Brass / Ceramic
Motor Pump Coupling / Pump RPM	Gearbox Drive / 1450RPM
Unloader Valve	Independent (Zero) (Panel Mounted)
Safety Valve	Yes

DIMENSIONS & WEIGHT

Machine Dimensions / Weight	760mm(L) x 585mm(W) x 900mm(H) / 65KG (approx.)
-----------------------------	---

WARRANTY(S)

Unit / Pump Warranty*	 2 Years
Engine Warranty*	 3 Years

OPTIONAL ACCESSORIES

30m Hose Reel w/30m hose	1060CMLP-HORJNR30M
JW Pro Turbo Head	JWA303-03
12" FSC - ABS Plastic	JWA-FSC12

The manufacturer reserves the right to modify design features and technical facts without notice, due to our principals of continuous improvement.

*Coverage against defects in material and workmanship (refer to Jetwave's and component partners T&Cs).

V2.3 02/22