

# EXECUTIVE™ SILENT 500-18



**7250**  
500 BAR  
**PSI**

**16**  
L/PM

**KOHLER KD1903**  
**42HP**  
**DIESEL**  
**ENGINE TYPE**  
KOHLER Diesel

**DIRECT**  
**1500RPM**  
**DRIVE**

**HOT**  
**WATER**  
**OUTPUT**



## HERO INNOVATIONS



**PEXO™**  
Enclosed Design



**JWPP™**  
Jetwave UDOR™ Italian Premium Pump



**INTELIUMS™**  
LCD Control System



**OLCE™**  
Oversized Liquid Cooled Engine



**ULDO™**  
Ultra Low Decibel Output



**CLASS B AS/NZS 4233.1**  
HIGH PRESSURE CLEANER  
RFID CERTIFICATION IS REQUIRED FOR OPERATORS



## APPLICATIONS

- Tradesmen
- Factories & Manufacturing
- Mine Sites
- Offshore Oil & Gas



## STANDOUT FEATURES

JW® UDOR® Premium Italian plunger pump running at 1500RPM direct with soft coupling to the engine, allows longer life and no reduction method.

Oversized Liquid Cooled Kohler™ KD1903 42HP diesel engine that optimises all speeds and loads.

IntelliUMS™ LCD Unit management system displays live data read outs, warnings and auto shutdown to protect the units critical components.

Sound proof cabinet ensures ultra low noise emissions approx 70dB allowing after hours cleaning in built up areas

Enclosed steel cabinet protection keeps all critical working components safe from weather and operator error.

Battery isolator & emergency stop. Lockable diesel fuel fill point for added safety.

## STANDARD EQUIPMENT



Gun: RL57 spray gun with built in swivel.

Lance: S3 1200mm stainless steel vented lance.



Hose: 15m non marking double wire braid hose w/M24 couplings.

## DIMENSIONS (MM)

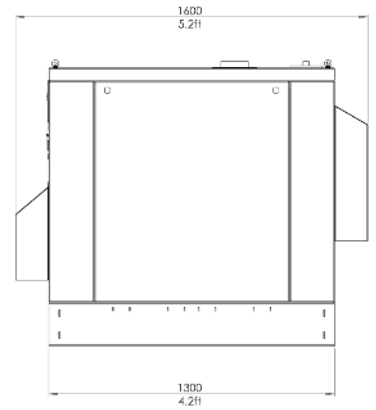

## TECHNICAL DATA

## EXECUTIVE SILENT 500-18

Product Code	HW7000-18DI
Pressure / Flow Rate	7250 PSI (500 BAR) / 18 L/PM (1080 L/PH) / 4.75 GPM
Max Water Inlet / Outlet Temp	60°C / 90°C
Class (ASNZS: 4223)	B (9,000 Bar/Litres)
Usage Frequency	Industrial: Continuous
Nozzle Size	O35
Frame Structure	CNC Modular skid galvanised steel chassis plus satin powder coat finish w/removable side covers

## MOTOR FEATURES



Engine / Power	Kohler™ KDI1903 Electric Push Button Start (liquid cooled) 42HP / 1861cc
Fuel Type / Capacity / Protection	Diesel / 100L (Common) / IntelliUMS™ Auto Shutdown Protection

## HYDRAULIC FEATURES



Pump / Head / Pistons	JW® UDOR® Premium Triplex Plunger / Brass (Nickle Plated) / Ceramic
Motor Pump Coupling / Pump RPM	Direct Soft Coupling / 1500RPM
Unloader Valve	Independent
Safety Valve	Yes

## HYDRAULIC FEATURES



Burner Model	Vertical 12v High Flow Series
Fuel Supply / Capacity / Consumption	Diesel / 100L / 5.74 L/PH
Coil / Housing Material	Mild steel 3mm wall seamless (500BAR rated) / Zinc coated steel

## DIMENSIONS & WEIGHT



Machine Dimensions / Weight	1600mm(L) x 1100mm(W) x 1300mm(H) / 633KG
-----------------------------	---

## WARRANTY(S)



Unit / Pump Warranty*	2 Years
Engine Warranty*	KOHLER.Diesel 3 Years

## OPTIONAL ACCESSORIES

## OPTIONAL UPGRADES

UR60 Turbo Nozzle (600 BAR)	25146035	Mine Specification Kit	SILENTMINESPEC
-----------------------------	----------	------------------------	----------------

Copyright © 2023 Jetwave® Group Pty Ltd. All Rights Reserved.

The manufacturer reserves the right to modify design features and technical facts without notice, due to our principals of continuous improvement.

\*Coverage against defects in material and workmanship (refer to Jetwave's and component partners T&Cs).

V3.0 08/23



303 Copland Street, East Wagga Wagga NSW 2650

equipment@amds.com.au

(02) 6921 2011 or 0428 212 011

www.amds.com.au